

# CLEAN COAL TECHNOLOGY PROGRAM

## Wanger Institute for Sustainable Energy Research (WISER)

Illinois Institute of Technology



### Vision

To continue the development of WISER's globally recognized program in Clean Coal Technology at Illinois Institute of Technology toward the realization of coal as a secure, environmentally safe, and economically feasible near-term supply option during the transition period from fossil fuel to totally renewable energy.

*"... finding safe, affordable, broadly deployable methods to capture and store carbon dioxide is clearly among the most important issues scientists have ever been asked to solve. We can, and should, and must strive to do so within the next 8 to 10 years."*

— Steven Chu, U.S. Secretary of Energy  
October 12, 2009

### Goal

The goals of the WISER Clean Coal Technology Program are to:

- Obtain the optimum design of coal conversion, integrated coal gasification combined cycles, and CO<sub>2</sub> separation using the Computational Fluid Dynamics (CFD) approach
- Develop cost-effective, novel sorbents and the most efficient processes for CO<sub>2</sub> removal
- Develop state-of-the-art, efficient, and economically feasible emission control processes for removal of environmental pollutants such as NO<sub>x</sub>, SO<sub>x</sub>, H<sub>2</sub>S, and mercury from the hot gas stream

### Strengths

The strengths of the WISER Clean Coal Technology program include a strong interdisciplinary team of engineering faculty with internationally recognized expertise in fundamental research, practical applications, and mathematical modeling in three core areas: CFD modeling and scale-up of gasification processes; CO<sub>2</sub> separation and sequestration modeling and experiments; and hot gas cleaning including mercury remediation.

#### —CFD Modeling and Scale-up of Gasification and CO<sub>2</sub> Separation Processes

Advanced design of coal conversion and gasification processes is being achieved using the computational fluid dynamics (CFD) approach. The CFD approach applies kinetic theory to gas/particle flow systems in the coal gasification processes to obtain optimum design. This research is considered to be one of the major contributions toward scaling up coal gasification processes from the laboratory and pilot level to the commercial level. Specific projects include:

- Based on the kinetic theory, WISER faculty developed a theory and model for the flow of multi-sized particles that is being used in the design of processes for coal gasification and separation of hydrogen from CO<sub>2</sub>. This model is being incorporated in the DOE's MFI (Multiphase Flow with Interphase eXchanges) computer program, developed at the National Energy Technology Laboratory.
- A new approach was developed to predict particle size distribution variation in the fluid/particle and fluidized bed processes due to particle reaction, agglomeration, and breakage by linking population balance equations with CFD. Using the method of moments in a finite-sized domain (FCMOM) and a complete set of orthogonal functions not only provides a highly efficient computational system, but also calculates reconstructed particle size distribution. This research represents a major fundamental step in enhancing the design and simulation of fluid/particle systems such as gas separation and coal gasification.

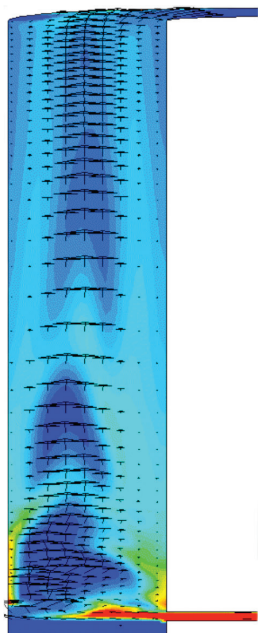

CFD simulation of the riser section of a circulating fluidized bed

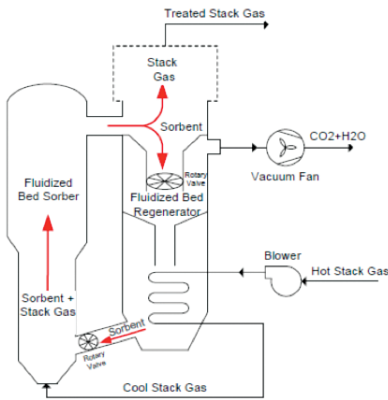

- A CFD model for the gasifier fuel cell was developed. Because molten carbonate and solid electrolyte fuel cells produce more than sufficient heat for coal gasification, WISER researchers have developed a concept to combine the endothermic gasifier and the exothermic fuel cell into one unit to achieve very high efficiency.
- Software modules are being developed to evaluate water management and potential freshwater reduction in power production plants using fossil fuels such as coal (in collaboration with Carnegie Mellon University faculty and National Energy Technology Laboratory).

### —CO<sub>2</sub> Separation

WISER researchers are working in several areas related to CO<sub>2</sub> removal from gas streams at elevated temperatures using durable and regenerable sorbents, as well as improving and optimizing gasification-based processes.

### —Hot Gas Cleaning and Mercury Remediation

WISER's Clean Coal Technology faculty have demonstrated significant research expertise in the removal of pollutants and toxic products of combustion and gasification processes, including:

- Development of highly reactive, durable, and attrition-resistant sorbents to remove H<sub>2</sub>S, SO<sub>x</sub>, and NO<sub>x</sub> from gas streams at high temperatures
- Removal of mercury emissions from coal-burning processes using an ultraviolet laser-light extinction technique to detect coagulation of powdered adsorbing materials
- Development of more reliable emission control systems

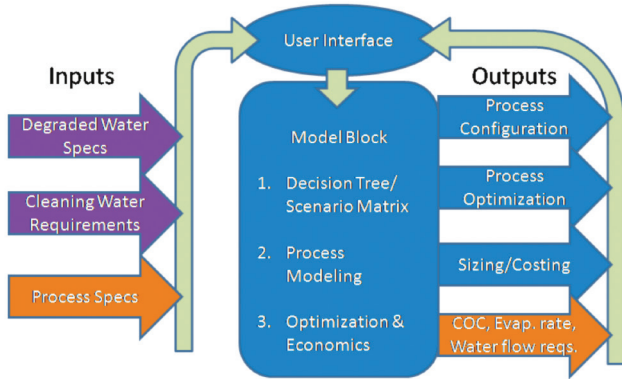

(top) Carbon dioxide capture using flue gas waste heat

(bottom) Modeling of water management and use of non-traditional water in power systems



[ WANGER INSTITUTE FOR SUSTAINABLE ENERGY RESEARCH ]

For more information, contact:

#### Hamid Arastoopour

Henry R. Linden Professor of Energy  
 Director, Wanger Institute for Sustainable Energy Research (WISER)  
 Illinois Institute of Technology  
 10 W. 33rd Street, Perlstein Hall Room 127  
 Chicago, Illinois 60616

phone: 312.567.3038  
 email: arastoopour@iit.edu

www.iit.edu/wiser